



EV Charger Instruction Manual

INSTRUCTIONS FOR INSTALLATION AND OPERATION

Safety and Warning

Save these instructions. Read all instruction before installing or using the charger.

Warning: Read all the instructions before using this product.

Warning: This device should be supervised when used around children.

Warning: The Wall Connector must be grounded through a permanent wiring system or an equipment grounding conductor.

Warning: Do not install or use the Wall Connector near flammable, explosive, harsh, or combustible materials, chemicals, or vapors.

Warning: Turn off input power at the circuit breaker before installing or cleaning the Wall Connector.

Warning: Stop using and do not use the Wall Connector if it is defective, appears cracked, frayed, broken, or otherwise damaged, or fails to operate.

Warning: Do not attempt to disassemble, repair, tamper with, or modify the Wall Connector. The Wall Connector is not user serviceable. Contact Tesla for any repairs or modification.

Warning: Do not touch the Wall Connector's end terminals with fingers or sharp metallic objects, such as wire, tools, or needles.

Warning: Do not insert foreign objects into any part of the Wall Connector.

Warning: Use of the Wall Connector may affect or impair the operation of any medical or implantable electronic devices, such as an implantable cardiac pacemaker or an implantable cardioverter defibrillator. Check with your electronic device manufacturer concerning the effects that charging may have on such electronic devices before using the Wall Connector.

Caution: Do not use private power generators as a power source for charging.

Caution: Incorrect installation and testing of the Wall Connector could potentially damage either the vehicle's Battery and/or the Wall Connector itself. Any resulting damage is excluded from the New Vehicle Limited Warranty and the Charging Equipment Limited Warranty.

Caution: Do not operate the Wall Connector in temperatures outside its operating

External Structure

Product Size

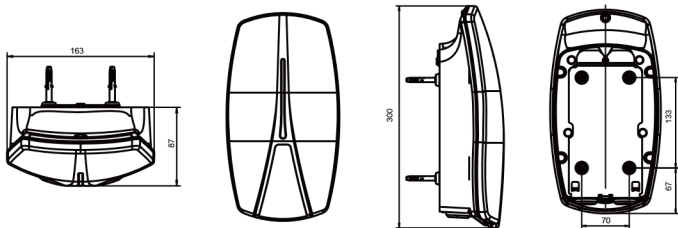











Introduction

Product Technical Specifications

Datasheet	Model	SWJ3E-7/32	SWJ3E-11/16	SWJ3E-22/32
Input	Power Supply	Single Phase	Three Phase	Three Phase
	Rated Voltage	220V~240V AC	380V~400V AC	380V~400V AC
	Rated Current	32A	16A	32A
	Frequency	50/60Hz	50/60Hz	50/60Hz
Output	Output Voltage	220V~240V AC	380V~400V AC	380V~400V AC
	Maximum Current	32A	16A	32A
	Maximum Power	7kW	11kW	22kW
User Interface	Charge Connector	Type 2 Cable		
	Cable Length	5m		
	Appearance Material	ABS+PC		
	LED Light	Green/Yellow/Red		
	RFID Reader	Mifare ISO/IEC 14443A(Max 5)		
Communication	Startup Mode	Swipe card to use/APP		
	External Communication	Wi-Fi 2.4G/Bluetooth		
	Leakage protection	TypeA+DC6mA		
Other Parameters	other production	Over Voltage、Over Frequency、Overload Protection, etc		
	IP level	IP65		
	Temperature	-30°C+50°C		
Environment	Humidity	5%~95%		
	Altitude	<2000m		
	Dimension	300*163*87 mm (H*W*D)		
Package	Package Dimension	525*420*150 mm (L*W*H)		
	Net Weight	5.5kg	7kg	7.5kg
	Gross Weight	6kg	7.5kg	8kg
	Panel Color (optional)	Black or Red or Blue or White or Silver		

Package Contents











Unpack the product. Please check and verify following items after receiving the charger :

		
<p>Base assembly+ Charging gun(x1) Connected</p>	<p>Upper cover(x1) Inside with two circuit boards</p>	<p>Panel(x1)</p>
		
<p>Top cover mounting screws(x6)</p>	<p>Base mounting screws(x1)</p>	<p>Under the base mounting screw(x1)</p>
		
<p>Bracket(x1)</p>	<p>Bracket fixing screw(x4 set)</p>	
		
<p>Crimp Terminal1(x5)/Crimp Terminal2(x5) Pick one of two</p>	<p>485 communication terminal(x1)</p>	

- Visual inspection on charger's external appearance. If there is any breakage or other damage, please notify the seller immediately.
- Check type and quantity of all accessories as follows. If there is quantity in short or type inconformity, make the record in time and contact the seller at once.

Operation Instruction

Installation Preparation

Tool Name	Photo	Function
Pencil or marker		–
Hammer		–
Wire stripper		–
Voltmeter or digital multimeter		To measure AC voltage at the installation site
Phillips screwdriver		–
Small flathead screwdriver		–
Ferrules		The diameter of the ferrule depends on the diameter of the power wiring and the construction
Wiring		Use twisted pair communication cable (Max diameter: 1.02 mm; Max cross-sectional area: 0.82 mm ²)
Machine drill		–
Crimping pliers		–
Twisted pair		If the meter is used for DLB control, the twisted pair shall be used for 485 communication

Installation Procedure

This charging pile equipment can only be installed, operated and maintained by professional and qualified personnel. The manufacturer is not responsible for any consequences arising from the use of this charging pile device. A Qualified Person is a person who possesses the certified skills and knowledge related to the construction, installation and operation of such electrical equipment and has received safety training to recognize and avoid the hazards involved.

Choose the Best Location for the Wall Connector. Determine the parking location of the vehicle to ensure that the charge cable reaches the charge port. The Wall Connector should be located:

- In an enclosed garage, typically on the vehicle's charge port side.
- In a well-ventilated area. Avoid installation in an enclosed box, or adjacent to hot appliances.
- 1.2 m above the floor.
- 190 mm from any obstructions to allow for cable looping.

step1 Fasten the hanging plate to the wall

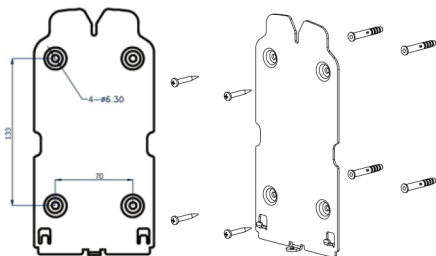

1. According to the size of the installation hanging board, drill holes for the fixed position of the wall. The positioning size and aperture of the installation hanging plate are shown in the figure.

Step2 Fix the body to the hanging plate

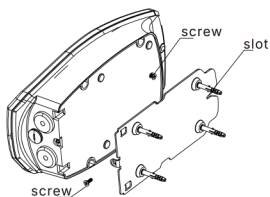

2. Punch the hole in the wall, insert the plastic head of the expansion screw, and install the hanging board on it, and then lock the plastic head against the installation hanging board hole through the expansion screw, so as to fix the installation hanging board on the wall.

step3 Wiring

Input method 1



Input

Line type	Length A	Length B
N-IN	40	15
L1-IN	50	
L2-IN	90	
L3-IN	100	
PE-IN	50	

Input method 2



Input

Line type	Length A	Length B
N-IN	35	6
L1-IN	45	
L2-IN	85	
L3-IN	95	
PE-IN	45	

Note:According to customer requirements, choose one of the two solutions

Output method (use for replacement)



Output

Line type	Length A
N-OUT	55
L1-0	75
L2-0	130
L3-0	155
PE-0	100
CP-0	130

The total wiring diagram

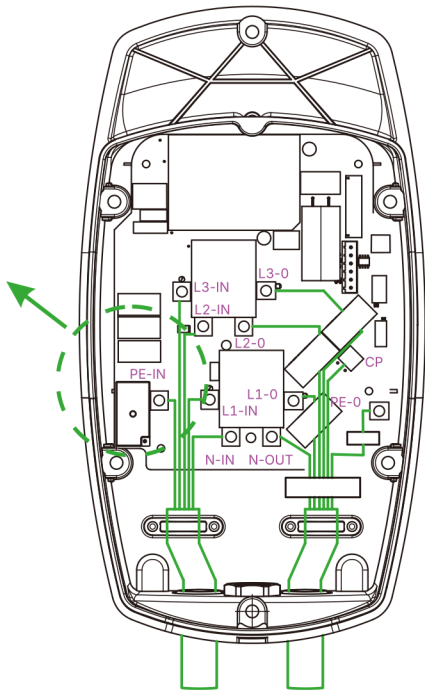
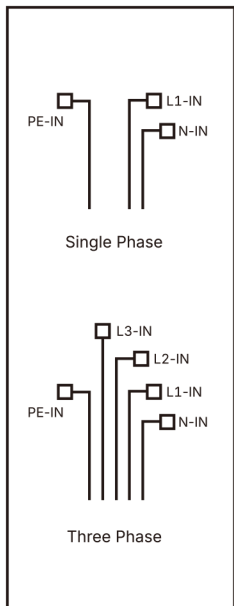

step4 DLB dynamic load balancing cable connection (optional)

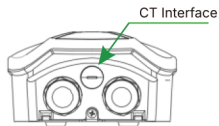

Model 1: Electricity meter wiring

- Single phase charger

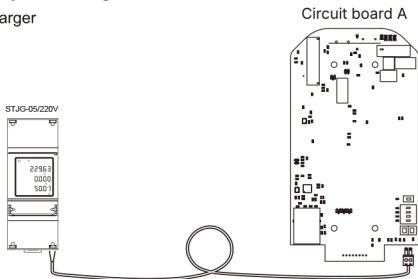

- Three phase charger

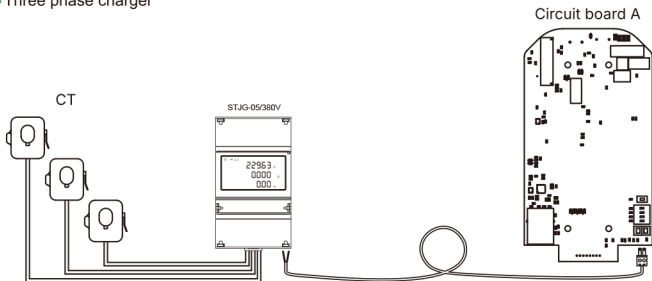

Note: According to customer requirements, choose one of the two solutions

Model 2: CT wiring
 • Single phase charger

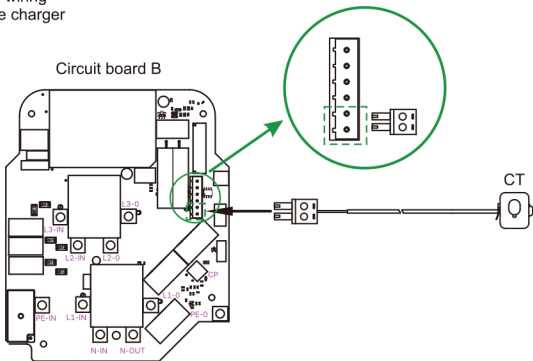

• Three phase charger

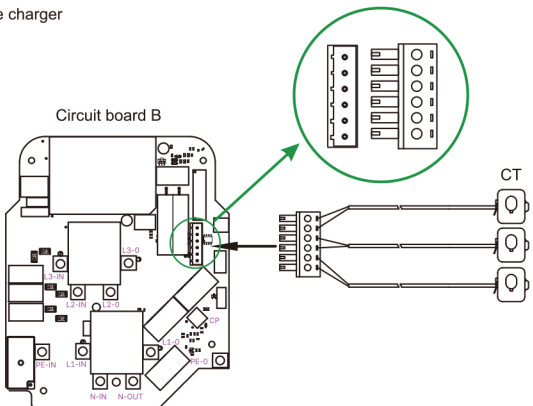

Note: According to customer requirements, choose one of the two solutions

step5 Set the operating current

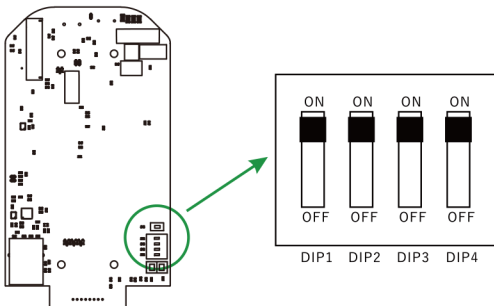

⚠ Warning: Power MUST remain OFF before setting or changing the DIP or rotary switches. Changing these switches with the power ON will not be recognized by the system and is dangerous due to the risk of electric shock.

1. Turn OFF power.
2. Use a non-conductive object to adjust the DIP switch settings.

DIP Definition			
DIP1	DIP2	Charge current selection	Note
OFF	OFF	10A	-
ON	OFF	16A	-
OFF	ON	13A	-
ON	ON	32A	Factory default
DIP3		Ground detection	Note
OFF		invalid	-
ON		valid	Factory default
DIP4		Socket selection	Note
OFF		OCPP Independent control	-
ON		APP+OCPP control	Factory default

step6 Schematic diagram of upper and lower plate connection

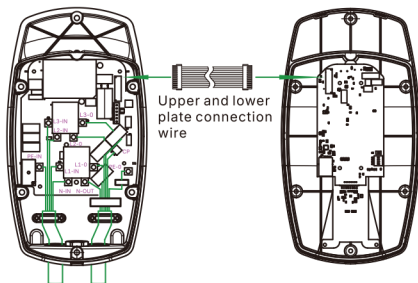

step7 Fix the cover to the body

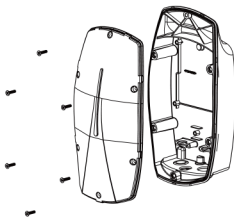

step8 Fasten the panel to the top cover

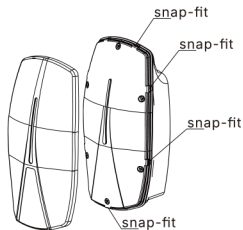

Panel disassembly: remove the buckle A, then B (left and right), and then push up to remove

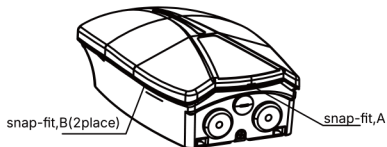

Configuration and Operation

Power on Inspection

- Check before startup

Before the first power on, please check / recheck the following:

- The location of the EV charger must have enough space to use, repair and maintenance.
 - Before installing the EV Charger, check the AC input components required for the correct installation protection.
 - Confirm again that the EV charger is installed correctly.
 - There are no components or other items left on the top of the EV Charger.
-

• Charging instruction

When charging, the LED indicator should be in standby mode.

Condition	Indicator condition
Blue, green and red lights fl ash alternately	Self-check
Blue light is always on	Stand by mode
Blue light fl ashing	Connection Confirmation
Green light is always on	Charging
Red light is always on	Over temperature protection
Red light fl ashing (3 fast and 1 slow)	Overcurrent Protection
Red light fl ashing (3 fast and 1 slow)	Leakage Protection
Red light fl ashing (3 fast and 2 slow)	Undervoltage protection
Red light fl ashing (2 fast and 2 slow)	PEN Function prtction
Red light fl ashing (4 fast and 1 slow)	Overvoltage protection
Red light fl ashing (6 fast and 2 slow)	Adhesion Protection
Red light fl ashing (7 fast and 1 slow)	Ground protection
Red light fl ashing (6 fast and 3 slow)	Electronic lock failure
Time long:2S on,0.5S o ff ; Time short:0.5S on,0.5S o ff ;	

Charging Operation

Insert the charger into the electric vehicle

- Insert the charging gun into the electric vehicle charger.
- After that, please check that the connector is connected correctly and tightly.
- After the connection is correct, the LED indicator of the charger will fl ash green, fl ash for 1 second, and turn o ff the light, indicating that the charger is ready to charge.

Start & stop charging

- Scan the NFC card in the identification area of the front to start charging, and the LED indicator will continue to light up gradually.
- When the electric vehicle is fully charged, the charging process will

Functional Specifications/User's Manual

Instruction

1. Network distribution method/Network connecting method

When the user supplies power to the Charger for the first time, it will enter the distribution mode, and the user can enter the major application platforms to download the "TUYA Smart" APP of the corresponding operating system.

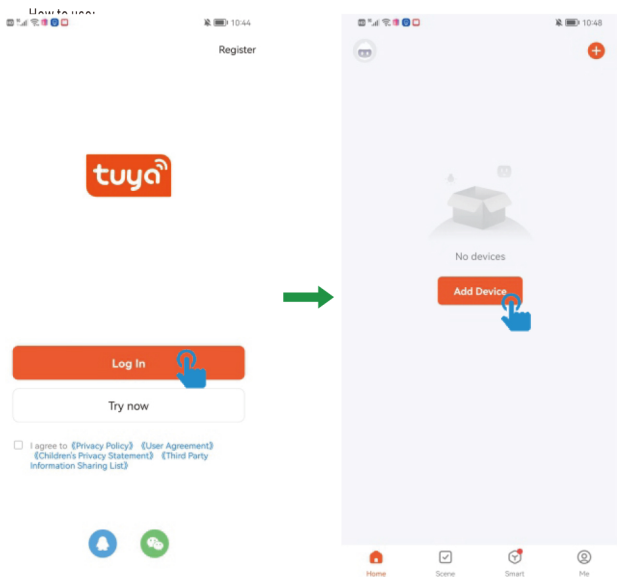

- Open Tuya APP
Enter the main page after login or registration

- Add device

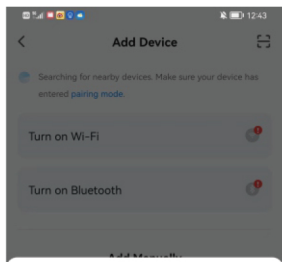
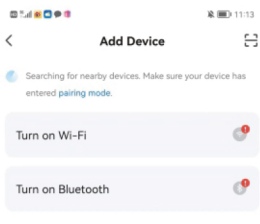

- Enable the permission

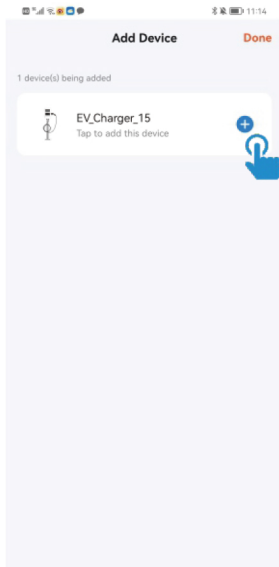
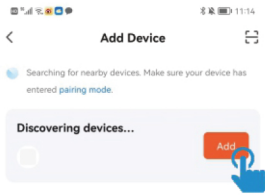

- Add the automatically discovered device

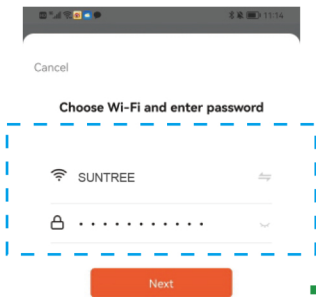

- Input WIFI to the device

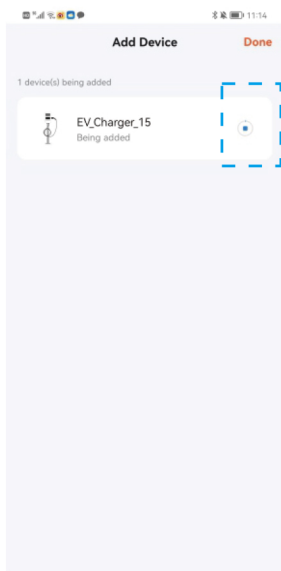

- Adding the device

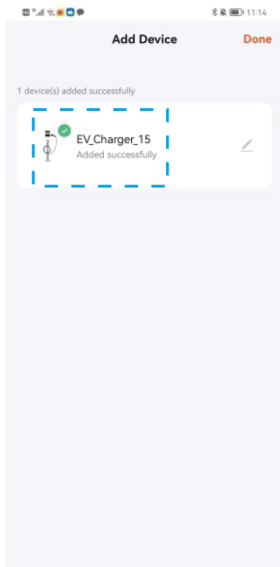

● Completed

Note: If the device cannot be found for a long time, first check whether the phone is connected to 4G or WIFI. When the link signal is stable, exit the APP and try to configure the network again.

2.Function Description

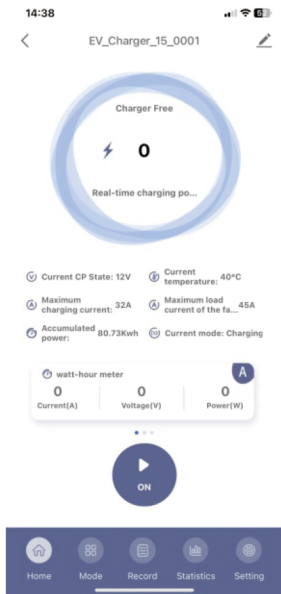

- Home page

-
1. Name of Charging station: "EV_Charger_15", user-defined.
 2. Charging status: Indicates the current charging process, including "not inserted gun", "inserted gun", "charging waiting", "charging in progress", "charging ended", and display of fault status.
 3. Real time charging power: The electrical energy used in a charging process (from starting to ending charging).
 4. Current CP status: CP voltage status of Charging station.
 5. Current temperature: internal temperature of Charging station.
 6. Maximum charging current: maximum charging current of Charging station.
 7. Maximum load current of the household: Maximum load current of the household circuit.
 8. Accumulated power: total power consumption of Charging station since delivery.
 9. Current mode: Charging mode: Indicates the current charging mode used, with three options: instant charging (entering the charging process by inserting the gun), normal charging (swiping the card or app to stop), and timed charging (setting the start time and charging duration, and automatically ending charging after reaching the set charging duration).
 10. Charging information: Display voltage, current, and power information during charging.
 11. Start charging: You can start and stop charging without swiping your card, and there is no need to draw a gun between the two charging processes.

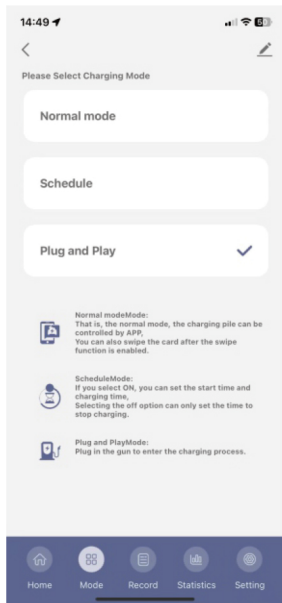

• Mode selection

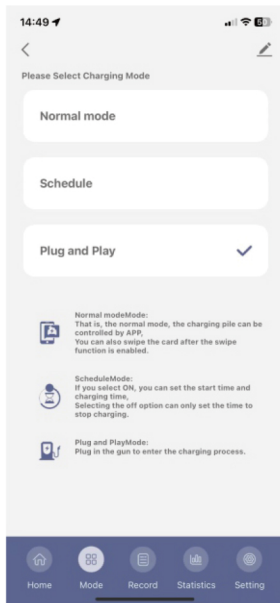

• Timed charging

Add timed charging: If you choose on, you can set the start time and charging duration. If you choose off, you can only set the time to stop charging. After the setting is successful, it is not recommended to cancel the timing within one minute before the time point set for the timing. Due to the delay of cloud processing, it may fail to cancel. If this extreme situation occurs, it is recommended to check the charging status on the main page to confirm that the Charging station is closed. If the timing cancellation fails, the Charging station

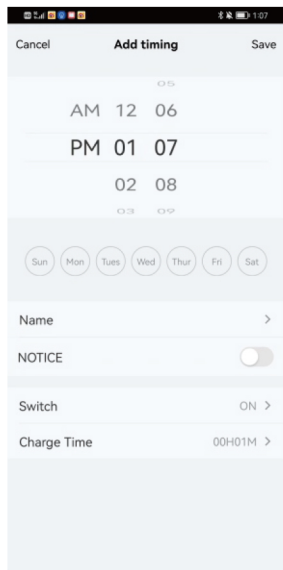

• Timing on



• Timed shutdown

Operation and fault records: You can view the recent device start and stop records and error log records.



• Operation log

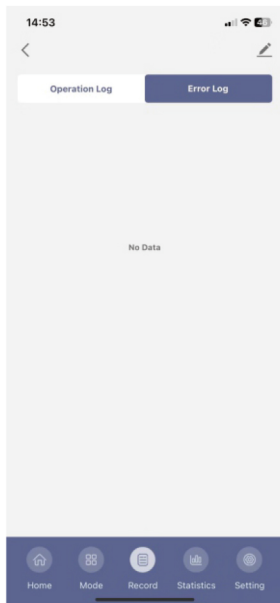

• Error log

Summarize and classify electricity consumption by year, month, and day, and display it in a curve chart

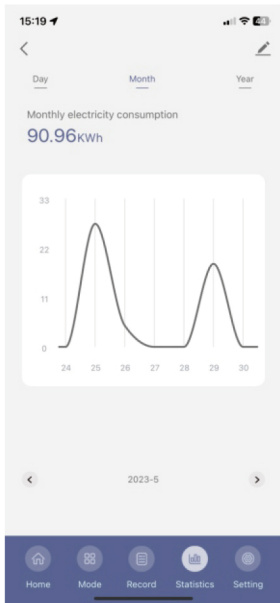

- Electricity statistics

Settings interface: can set card swiping charging function, maximum charging current adjustment, DLB function, Pen function, preset timing, OCPP, etc

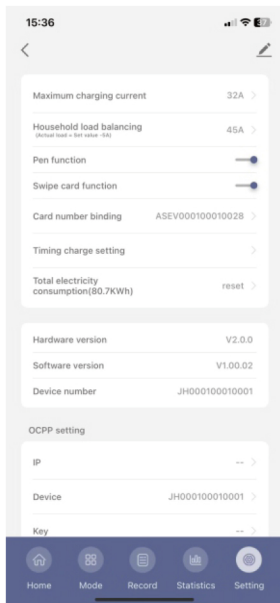

- Setting interface

-
1. Maximum charging current setting: adjust the output capacity of the Charging station. The default output current of the Charging station is 32A. The available options range from 6A to 32A. Select the corresponding current value and click OK
 2. Home Load Balancing (DLB) Settings: Set the maximum load current of the home circuit, with a default value of 45A and an optional range of 10A~140A
 3. Pen function: Users can activate the Pen protection function themselves
 4. Card swiping function: Users can enable the card swiping function on their own. When the function is enabled, the next line will display the "Card Number Binding" information bar
 5. Timing charging setting: Users can preset the start and end time of timing charging, etc
 6. Total electricity consumption: cumulative electricity consumption statistics of Charging station, users can reset
 7. Equipment information column: including Charging station hardware version number, Software versioning and equipment number
 8. OCPP settings: Users can set the IP and key required for the OCPP protocol, and the device number can be edited

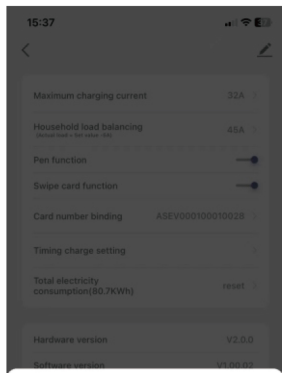

Maximum charging current

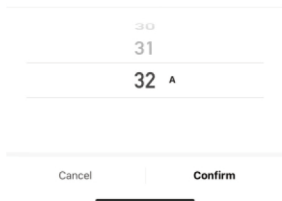

- Set maximum charging current

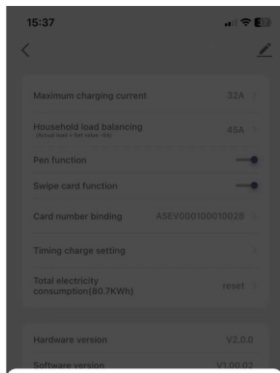

Household load balancing

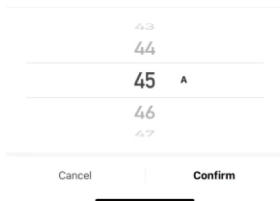

- Set Home Load (DLB)

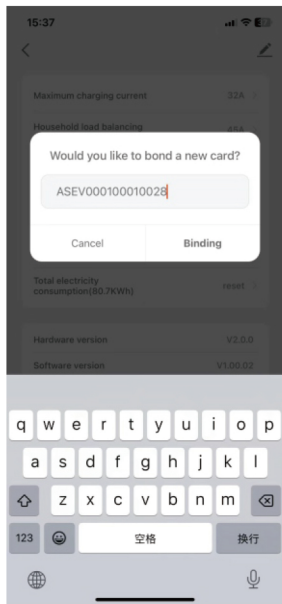

• Bind RFID card

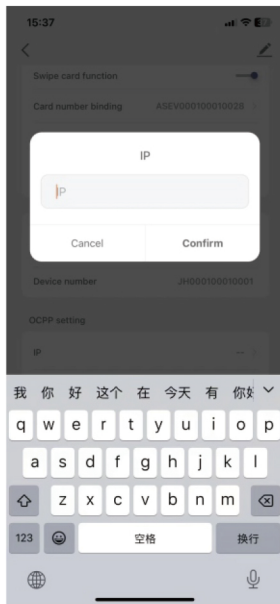

• Set IP (OCPP)

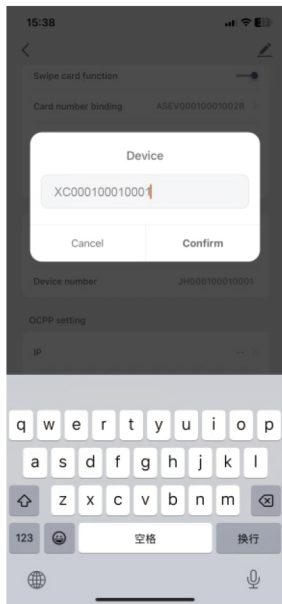

• (OCPP)Edit device number

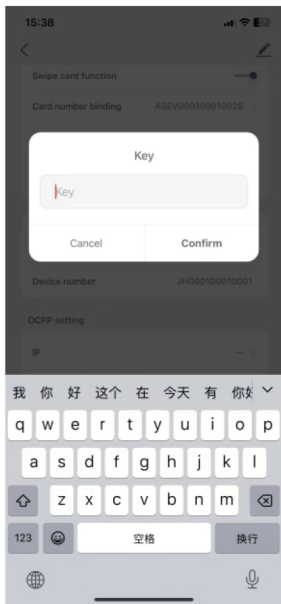

• Set Key (OCPP)

Setting :It can bind the user card, switch the charging current, and view the basic information of the charger.

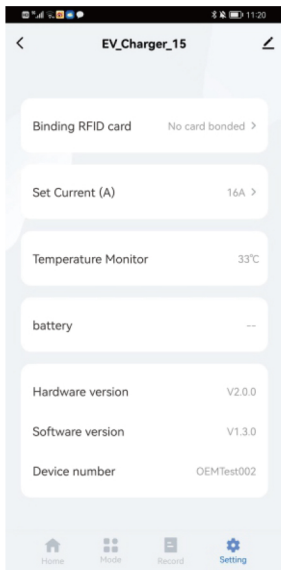

• Setting

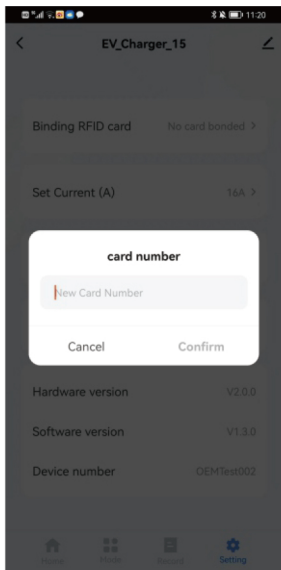

• Card binding

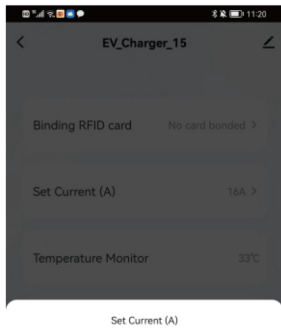

• Switch the current

- 1) Card binding: the user can input the charging card number to be bound (see the cover of the charging card for details), and then the user can swipe the card offline for charging.
- 2) Current setting: Adjust the output capacity of the charger. The default output current of the charger is 32A, and the available options range from 6A to 32A.
- 3) Hardware version: Hardware version of the current charger.
- 4) Software version: Software version of the current charger, which can be upgraded remotely through APP
5. Device No. : unique factory identifier of charger.

3.Graffiti APP management interface

Users click on the edit icon in the upper right corner to enter the graffiti app management interface

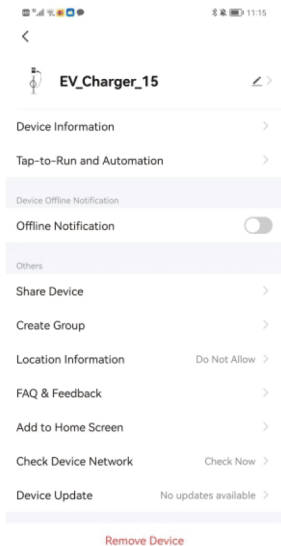

- APP management interface

Device Name: The initial name defaults to EV_ Charger_ 15. Users can customize, edit, and modify

Device sharing:Click on device sharing to share the device with other accounts through a graffiti smart account or other related software for shared use of the device (it is recommended to use a graffiti smart account for sharing).

Setting of TUYA APP

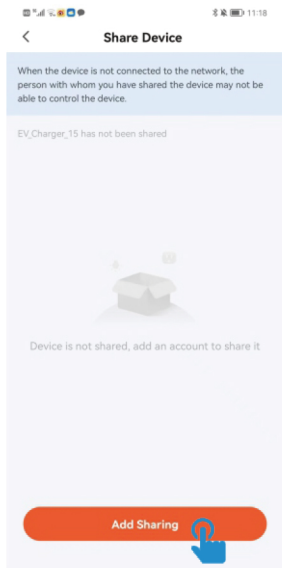

- Click to add sharing



- Click to share TUYA account

Setting of TUYA APP

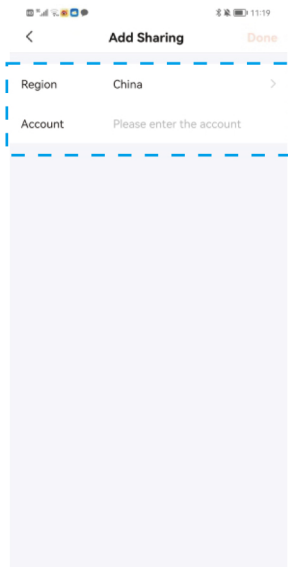

- Enter TUYA account complete

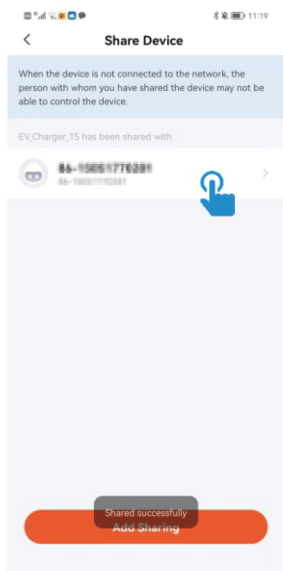

- Display on the sharing side

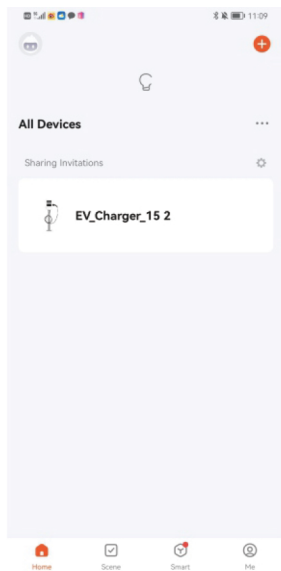

- Click the device icon in the sharing side to automatically connect the charger and enter the home page after successful connection

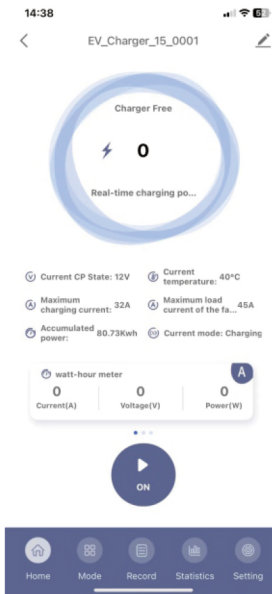

- Home page on the sharing side

- DLB fuction

Optional function, which is a power management function, can self-adjust the output current, so that the total household electricity load does not exceed the total household current. CT is installed on the firing line of the household main incoming line (or for three-phase power, each live wire needs to be installed with a CT), and the current output is detected in real time to adjust the output current of the charger in real time.

The total current of HOME incoming line can be set through the APP , and the path is "TUYA -APP home page - Setup - Card Binding - Command input". Enter "HOME value" in the command input field and confirm to complete the setting of the upper limit of the total current of HOME incoming line, and the input value is the upper limit.

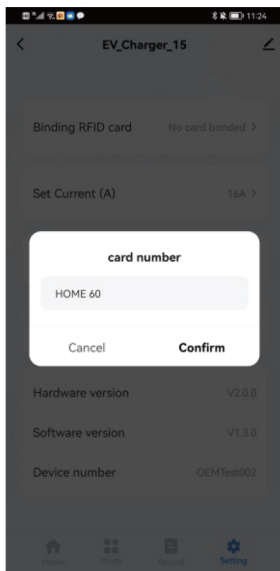

- Load balancing settings

Note:

1) If the current values of three firing lines detected by three-phase power are not equal, the product will self-calculate the minimum output current, and the three output lines will be executed according to this minimum output current.

2) When the DLB is not installed, the charger will output with the maximum allowable current, which is fixed and will not be adjusted automatically unless adjusted by external control.

3) DLB Function:

The current value of the home + the current value of the charger exceeds 2A of the total current of the home line, and the current value set by the charger is greater than the actual current value of the charger. In this case, DLB is adjusted. For example, set the total current of the HOME incoming line "HOME 32A" (the charger actually takes the maximum current value of -5A as the maximum input value of the HOME, so as to prevent load balancing failure and reserve 5A). Therefore the total current of the HOME incoming line is $32A - 5A = 27A$;

The default charging current of the charger is 32A, and there is 8A load in the family. At this time, the theoretical current value is: $32A + 8A = 40A$, which exceeds the total allowable value of the family (27A) 13A, and the current of the charger will decrease by 13A to 19A

When the condition current of DLB changes for more than 2A and lasts for more

▪ RFID Function

The charger has a card swiping board inside, through the external card swiping to implement the device starting and stopping vehicle charging.

(Enter the 16-digit card number in the APP card binding page, and bound the RF card)

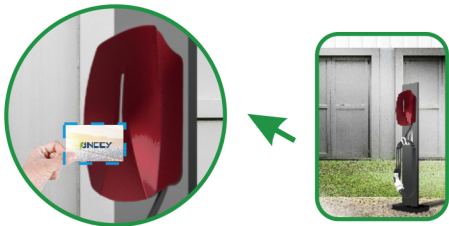

Troubleshooting

Fault Codes and Solutions

Failure	Solutions
Leakage self-test	<ol style="list-style-type: none"> 1. Check whether the leakage transformer is connected normally 2. After the leakage transformer is connected normally, power on again, check the fault status
Emergency stop	<ol style="list-style-type: none"> 1. Check if the emergency stop button is pressed 2. Check whether the emergency stop is connected to the corresponding position 3. Check if the emergency stop is connected to the normally closed contact
Leakage	<ol style="list-style-type: none"> 1. Check whether the leakage current transformer is connected normally 2. Check whether the leakage transformer model is the same 3. Check whether the leakage transformer wiring harness is normal or not 4. Leakage fault during charging needs to be powered off to restore
CP abnormal	<ol style="list-style-type: none"> 1. Check if the gun wire is connected 2. Check if CP is recovered after pulling the gun 3. Check if there is a loop between CP and PE
Over-current	<ol style="list-style-type: none"> 1. Check the rated power of the EV charger 2. Check the resistance of load terminal 3. Overcurrent fault will be clear after pulling out the gun
Over-voltage	<ol style="list-style-type: none"> 1. Check whether the input voltage is normal 2. Use a multimeter to check whether the input L-N voltage is normal (three-phase EV charger need to detect L1\L2\L3 respectively) 3. overvoltage will be clear after the voltage is restored
Undervoltage	<ol style="list-style-type: none"> 1. Check if the input voltage is normal 2. Use a multimeter to check whether the input L-N voltage is normal (three-phase EV charger need to detect L1\L2\L3 respectively) 3. under voltage will be clear after the voltage is restored
Adhesion	<ol style="list-style-type: none"> 1. After the power is off , use a multimeter to check whether the input L and output L are short-circuited or not; check whether the input N and output N are short-circuited or not (three-phase piles need to detect L1\L2\L3 respectively) 2. If there is no short circuit, turn on the power again after pulling out the gun, and check whether the adhesion fault is eliminated. If it is not eliminated, it is recommended to perform the third step 3. If there is a short circuit or the fault is not eliminated, remove the gun wire LN, power on again, and check whether the fault is cleared. 4. If the fault is still not cleared, please send the control board to supplier for analysis 5. Before charging, the adhesion fault needs to be powered on again to clear the fault

Ungrounded	<ol style="list-style-type: none"> 1. Check whether the input terminal is connected to PE normally 2. Use a multimeter to check whether the input L-PE and N-PE voltages are normal (three-phase EV Charger needs to be tested for L1\L2\L3 respectively) 3. Ungrounded fault during charging ,Pull the gun to clear the fault
Card reader abnormal	<ol style="list-style-type: none"> 1. Check if the card reader is connected properly 2. Check if the status light on the card reader is on 3. Replace the card reader and power on again 4. During Charging, The card reader must be offline and needs to pull out the gun to clear the fault
EEP self-test failed	<ol style="list-style-type: none"> 1. Check whether components are damaged or missing 2. Contact after-sales staff for processing
FLASH self-test failed	<ol style="list-style-type: none"> 1. Check whether components are damaged or missing 2. Contact after-sales staff for processing

Note: If the above problems cannot be solved, please contact the seller.